

# Wolflite H-251MK2 Handlamp

Zones: 1 and 2



## Product Overview

The Wolflite H-251 MK2 is a rechargeable handlamp approved by BASEEFA and suitable for use in hazardous zones 1 and 2.

Applications include the petrochemical and offshore industries, fire-fighting, gas and water distribution, wherever a potentially explosive atmosphere may occur.

The H-251 MK2 is constructed in highly durable polypropylene co-polymer, designed to withstand the effects of heavy industrial use. The glass lens is scratch and scuff resistant and will not discolour when in contact with chemicals. The entire product has been 'drop' tested for damage and both the outer and inner components proved equally highly resilient. Many unique design features are incorporated in the H-251 MK2 including; an interlock mechanism preventing internal access when the lamp is in use, short circuit protection via a ceramic fuse and a magnetically operated, hermetically sealed Reed Switch to avoid open internal sparking. The rechargeable battery pack is made up of two sealed lead acid cells assembled into a robust casing. This battery pack has a recharge/discharge life of approximately 500 cycles.

The H-251 MK2, has charging contacts on the base of the lamp to enable battery charging 'in situ' using the lamp charger. The H-251 MK2 chargers are available for mains (120/230v) or low voltage (12-32v) input for use in vehicles. All chargers have LEDs which indicate state of charge, a rating plate on the charger explains the sequence of this. The H-251 MK2 conforms with the DOT Class I 'Safety Lamp' specification, Regulation 17 of the SOLAS protocol and has been issued with a Lloyds Register of Shipping Type Approval Certificate. The H-251 MK2 is supplied complete with battery pack, lock key and shoulder lanyard, together with maintenance instructions giving comprehensive details of spares available and guidance for installation.

## Features & Benefits

- Long-life High Output Krypton Bulb
- Sealed Lead Acid reliability
- User and Maintenance Friendly
- Reliable Efficient Chargers
- Lloyds Register Type Approved
- Suitable for Cyclic and Short Term Standby Applications (for Long Term see Wolflite XT Rechargeable LED Handlamp and Rechargeable Torch)

## Certifications

EX (NON ATEX)



**Distributed by:**  
Safety Lamp of Houston, Inc.  
1816 Rotary Dr.  
Humble, TX 77338

P: (281) 964-1019  
F: (281) 964-1040  
E: [sales@safetylampofhouston.com](mailto:sales@safetylampofhouston.com)  
W: [www.safetylampofhouston.com](http://www.safetylampofhouston.com)

# Technical Specification

<b>Product Reference</b>		<b>H-251MK2</b>
<b>Product Description</b>		Rechargeable Safety Handlamp, Battery Charged Internally
<b>Code</b>		EEx e s II T3
<b>Type of Protection</b>		"e" increased safety, "s" special protection
<b>Area of Classification (Gas)</b>		Zones 1 and 2, Gas Groups IIA, IIB, IIC
<b>Temp. Classification (Gas)</b>		T3
<b>Ambient Temperature</b>		-20°C to +40°C
<b>Certificate</b>		BASEEFA Ex 81142
<b>Enclosure</b>		Polypropylene
<b>Lens</b>		Toughened Glass (6mm)
<b>Beam Type</b>		Spot
<b>Light Source</b>	<b>Part Number</b>	<b>H-26P</b>
	<b>Type</b>	Krypton Filled Filament Bulb
	<b>Volts</b>	3.6V
	<b>Watts</b>	3.6W
	<b>Output</b>	80lm (at 4.1V)
	<b>Life</b>	100hrs
<b>Power Source</b>	<b>Part Number</b>	<b>H-16E</b>
	<b>Type</b>	Rechargeable Battery, Sealed Lead Acid
	<b>Volts</b>	4V
	<b>Capacity</b>	5Ah
	<b>Life</b>	Up to 500 Recharge Cycles
<b>Light Duration</b>		4-5hrs
<b>Ingress Protection</b>		IP54
<b>Weight</b>		1.5Kg (incl. battery)
<b>Compatible Charger</b>		<b>C-251 HV or C-251 LV</b>

- All information has been gathered under laboratory conditions, the user must regard the values given as approximate.
- Changes may be made to the above specification without notification, details are available on request.

## Product Dimensions

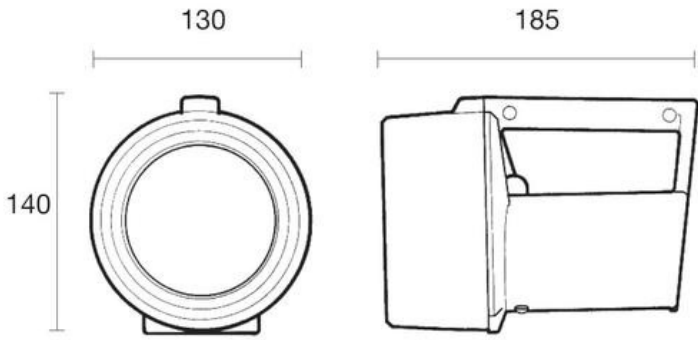

## Light Output

3.6W Spot Beam (approx. 3°)  
Peak luminous intensity at 5m **900lux**

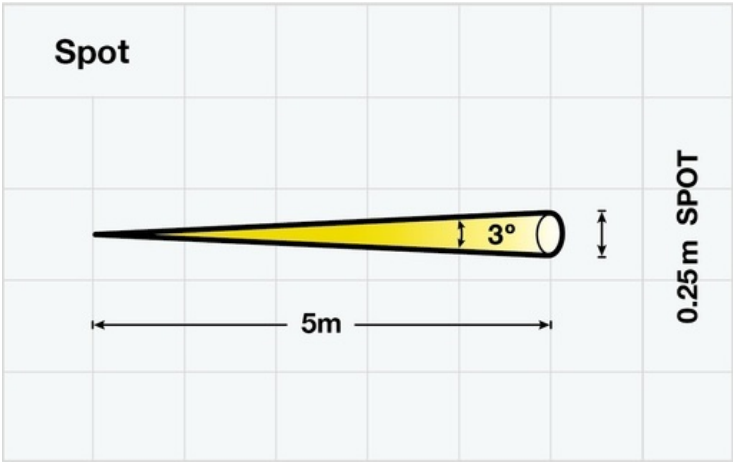

Version: SL031 DF 425 Issue 3



Wolf Safety Lamp Company, Saxon Road Works, Sheffield, S8 0YA, UK  
T: +44 (0) 114 255 1051 F: +44 (0) 114 255 7988  
E: info@wolf-safety.co.uk www.wolf-safety.co.uk

